

# DEUTZ BFM 1013

For mobile machinery ■ 92 - 223 kW | 123 - 299 hp at 2000 - 2300 min<sup>-1</sup> | rpm ■ EU stage II / US EPA Tier 2

- Water-cooled 4 and 6-cylinder inline engines with turbocharging and charge air cooling
- The robust engine design allows worldwide operation even with high sulphur fuels.
- The compact engine design and three PTO drive possibilities integrated into the gear drive reduce the installation cost and increase the number of applications.
- Best cold starting performance even under extreme conditions.
- Low noise emissions due to acoustically optimized components with very smooth running and high durability.
- Wet cylinder liners, long oil change intervals and easy changing of the engine fluids reduce the running and service cost and increase the availability of the machinery.
- Also available with an electronic motor regulator (EMR) to allow easy integration into the electronic device control and monitoring system.

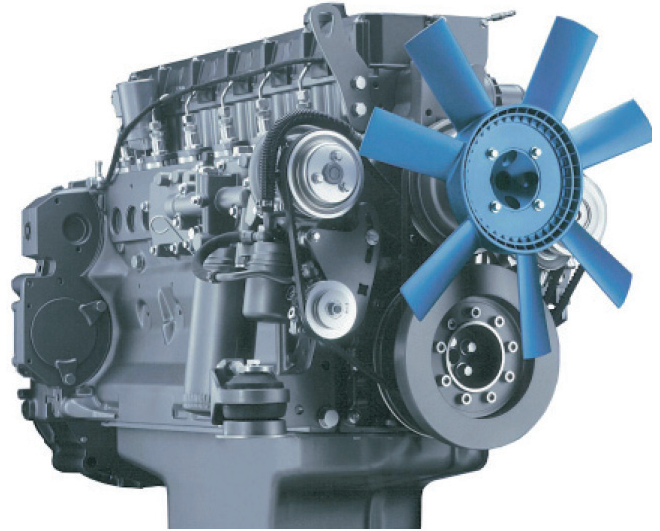

## TECHNICAL DATA

Engine Type		BF4M1013EC	BF4M1013FC	BF6M1013EC	BF6M1013FC
No. of cylinders		4	4	6	6
Bore/stroke	mm   in	108/130   4.3/5.1	108/130   4.3/5.1	108/130   4.3/5.1	108/130   4.3/5.1
Displacement	l   cu in	4.8   292.9	4.8   292.9	7.2   439.4	7.2   439.4
Maximum nominal speed	min <sup>-1</sup>   rpm	2300	2300	2300	2300

Engine Type		BF4M1013EC	BF4M1013FC	BF6M1013EC	BF6M1013FC
Power output as per ISO 14396	kW   hp	118   158	118   158	174   233	200/223 <sup>4)</sup>   268/299
at speed	min <sup>-1</sup>   rpm	2300	2300	2300	2300
Max. torque	Nm   lb/ft	577   426	700   516	854   630	1050   774
at speed	min <sup>-1</sup>   rpm	1400	1400	1400	1400
Minimum idling speed	min <sup>-1</sup>   rpm	650	650	650	650
Specific fuel consumption <sup>2)</sup>	g/kWh   lb/hph	205   0.337	204   0.335	205   0.337	195   0.321
Weight as per DIN 70020 Part 7A <sup>3)</sup>	kg   lb	432   952	432   952	572   1261	572   1261

1) Power data without deduction of fan power.

2) Best full load consumption refers to diesel with a density of 0.835 kg/dm<sup>3</sup> at 15°C | 6.96 lb/US gallon at 60°F.

3) Without starter/alternator, cooler and fluids but with flywheel and flywheel housing.

4) Exceptional output.

## CHARACTERISTIC CURVES

BF4M 1013 EC - 118 kW  
BF4M 1013 FC - 129 kW

BF6M 1013 EC - 174 kW  
BF6M 1013 FC - 200 kW / BF6M 1013 FC - 223 kW

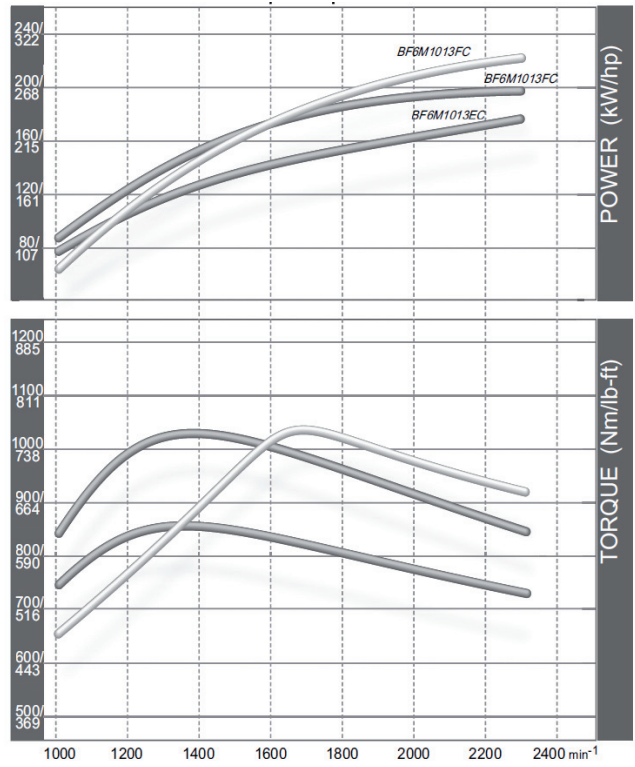
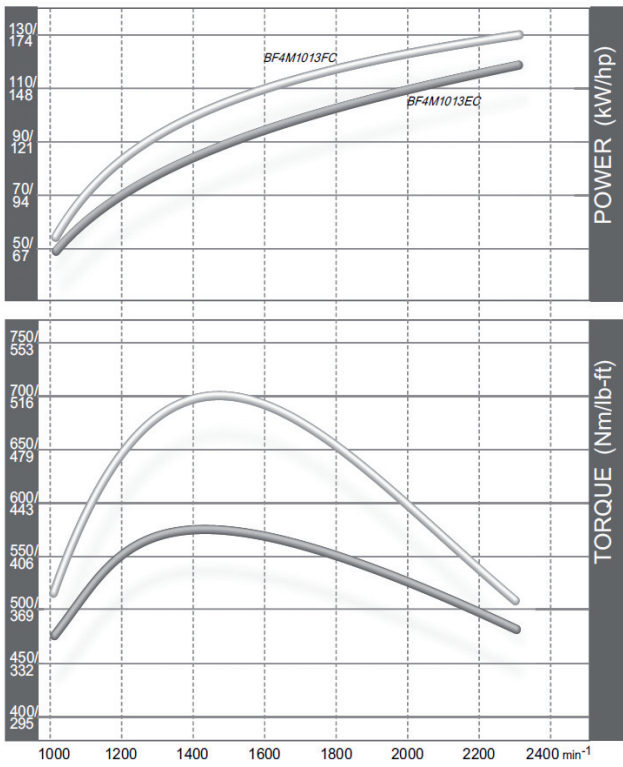

## DIMENSIONS

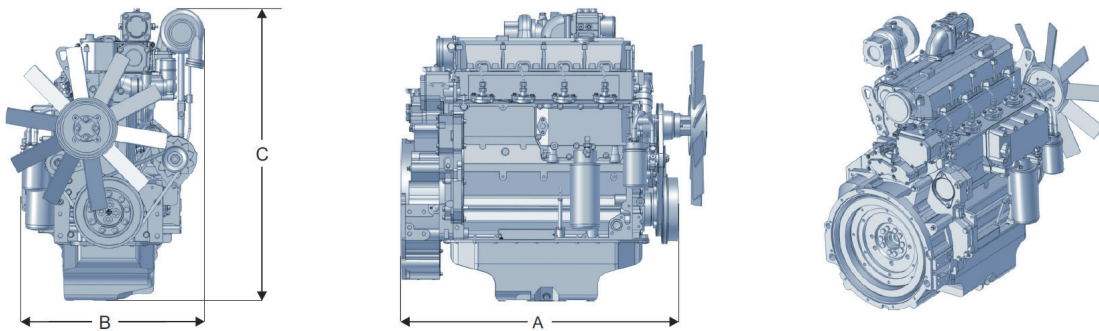

Engine Type		A	B	C
BF4M 1013 EC / FC	mm   in	895   35.2	634   25	940   37
BF6M 1013 EC / FC	mm   in	1162   45.7	683   26.9	990   39

Note: Preliminary technical data. The engine dimensions and weights vary depending on the scope of delivery.

The data on this data sheet are for information purposes only and are not binding values. For more information please contact your responsible sales partner.

**DEUTZ AG**  
Ottostraße 1  
51149 Cologne, Germany  
Phone: +49 (0) 221 822-0  
Telefax: +49 (0) 221 822-3525  
E-Mail: info@deutz.com  
www.facebook.com/deutzofficial  
www.deutz.com

The engine company. 