



## MCflex

The MCflex unit offers a multitude of functions for the control and monitoring of conventional but also electronically-controlled diesel engines. You can individually configure the settings for very diverse applications and different engine variants.

### APPLICATIONS

Diesel engines in applications for industry

Communal vehicles

Agricultural machines

Construction machinery

Special-purpose vehicles and machines

**Transflective, backlit B/W display with automatic contrast adjustment**  
MCflex ensures perfect legibility even under poor lighting conditions.

**UV-resistant, rugged PA6 housing. Secure installation with retainer or screw-fastening, 3 x M6**  
Fast installation and retrofit. Dependable functioning even in harsh environments.

**Communication via CAN bus with the network**  
Integration of conventional engines in existing CAN bus networks and applications.

**Pin assignments of the outputs are freely parametrisable. Up to 5 high-current outputs.**  
Flexible utilisation of the MCflex functionalities, tailored to the customer application. Output parametrisation with the display menu or the convenient ehbTools software. No programming required.

**Pre-heat, by-glow and after-glow function, time- or temperature-controlled**  
Reliable starting process, even at very low temperatures. Less environmental impact and smoke generation.

**Total operating hours counter and resettable daily operating hours counter**  
Reliable information about engine running times and required servicing. Transparent summary of operating times.

**Password-protected menu settings and automatic logging of the last 20 faults**  
Access to relevant functions restricted to authorised personnel. Reliable reproduction of faults occurred.

**With or without ignition starter switch**  
An ignition starter switch starts the engine either per key or electronically, that is key-less. For the key-less version, entering a release code via a start button initiates the start.

## MCflex TECHNICAL DATA

ehb5200 (standard version)  
ehb5175 (keyless)

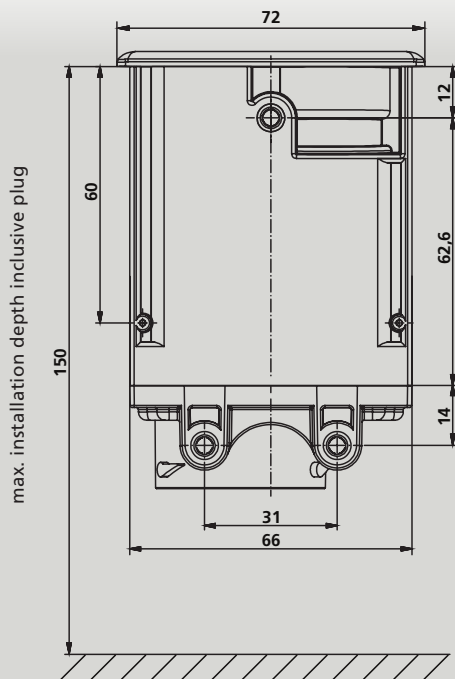

### Electrical data

Voltage range	6 – 32V (typ. 12 – 24V)
Power consumption	50mA typical (in UB 8 – 24V)
Operating temperature	-20°C to +70°C
Storage temperature	-30°C to +80°C
Inputs	PIN 01: Oil pressure as NO/NC, programmable, switching or analogue sensor   PIN 02: Generator monitoring, terminal D+   PIN 03: Temperature as NO/NC, programmable, switching or analogue sensor   PIN 04: Various, NO/NC   PIN 07: Auto start, NO/NC   PIN 09: External stop, NO/NC   PIN 13: Speed monitoring, terminal W, Sensor or magnetic pick-up
Outputs	All outputs are short circuit-proof   PIN 02: Generator excitation, terminal D+, 0.5A   PIN 06: Freely parametrisable, 7.5A (max. 1s) / 6.0A   PIN 08: Freely parametrisable, 40A (max. 1s) / 20A   PIN 10: Freely parametrisable, 70A (max. 1s) / 35A   PIN 11: Freely parametrisable, 40A (max. 1s) / 20A   PIN 12: Freely parametrisable, 70A (max. 1s) / 35A   PIN 15: Freely parametrisable, 3.5A (max. 1s) / 3.0A   PIN 18: Freely parametrisable, 40A (max. 1s) / 20A
CAN bus interface	PIN 17 / 19, CAN2.0B, 250kBit, SAE J1939 EEC1, ET1, EFL/P1, VEP1, AMB, DM1, fault messages / auto start, speed adjustment, optionally adaptable
Operating hours counter	Integrated
Daily operating hours counter	Integrated

### Visualisation

Display type	Dot-matrix LCD display, transfective Dark-blue representation on grey background
Resolution	16 x 2 characters, 5 x 8 dots per character
Brightness	>1000 cd/m <sup>2</sup>
Contrast ratio (CR)	8.24
Background lighting	LED, white

### Mechanical data

Housing dimensions (L x W)	72 x 72 mm
Installation dimensions (W x H x D)	66 x 66 x 130 mm
Installation cut-out (W x H)	66 x 66 mm
Housing material	PA 6 30 GB, black, UV-stabilised
Weight	340g
Installation	Retainer or screw-fastening, 3 x M6
Degree of protection:	IP67
Connection	Deutsch plug type HDP24-24-19PE

### Test standard

Humidity	DIN EN 60068-2-3
Vibration	DIN EN 60068-2-6
Impact	DIN EN 60068-2-27
CE marking	according to Directive 2014/30/EU

### Accessories

Connection cable, 19-pole, 3m	ehb2268
Deutsch plug set	ehb1469
CAN dongle with ehbTools PC software	ehb5365
MCflex starter kit CAN dongle, ehbTools, connecting cable, power supply unit	ehb5378

